

# Flettner TCX™ Ventilator



Thank you for purchasing the most advanced wind powered rotary ventilator available. The **Flettner TCX™** provides high performance air extraction and is designed to be extremely reliable. Properly installed, it will provide years of maintenance-free ventilation.

## VERY IMPORTANT – Read this first

Adequate ventilation is vital. It is the responsibility of the fitter and the customer to establish the amount of air extraction that is required for each application, and to ensure that the positioning and the number of ventilators fitted are suitable.

*As a guideline only air extraction rates measured by MIRA Ltd. are published on the Flettner Ventilator web site: [www.flettner.co.uk](http://www.flettner.co.uk) These are provided purely for illustrative purposes as the extraction rates achieved are dependent upon the precise configuration of each application.*

The performance of the Flettner TCX™ will be impaired if it is fitted to a sealed vehicle compartment or to a building with no independent air inlet. In such situations an air inlet such as a grille should be fitted in addition to the Flettner TCX™ in order to provide an adequate path for air extraction to occur.

If the ventilator is used to extract hazardous vapours then continuous ventilation is required. In such circumstances remove the blue sliding element from the shutter to prevent accidental closure.

## Contents

The following items are supplied as part of the **Flettner TCX™** ventilator:

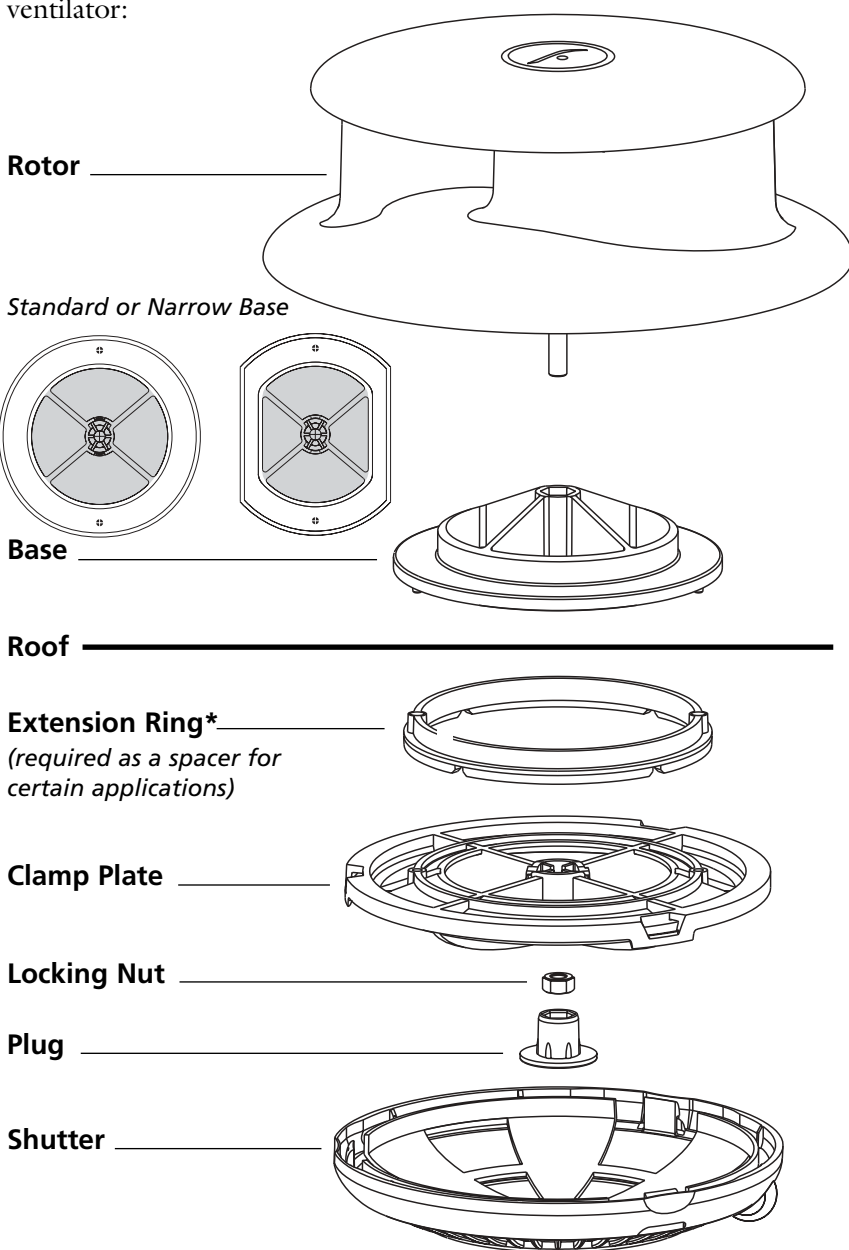

\*The extension ring is not usually required but can be used as a spacer between the clamp plate and the roof in situations where obstructions would prevent the clamp plate and shutter from fitting flush with the roof.

# Fitting Instructions

If the ventilator is to be fitted to a ribbed section of a roof ensure that the base of the ventilator can sit flush on the roof surface between the ribs, and that the position chosen will permit the clamp plate and shutter to sit flush with the underside of the roof.

For most applications the standard base is suitable, but in some cases the narrow base option is required. For double-skinned roofs an adaptor (optional extra) should be used.

- Using one of the templates supplied (**Figures 2 and 3**) mark out on a flat section of the roof the hole pattern corresponding to the correct base option. Ensure the position chosen allows sufficient clearance in each direction for the base and rotor to be located properly.
- Drill the two 5.0mm (0.20") diameter locating holes. The centres of the two holes should be 124.0mm (4.88") apart, equally spaced on either side of the large hole on a line passing through the centre of it.
- Cut the large hole – either a Ø98.0mm (Ø3.86") circular hole or an oval hole as shown in **Figure 3**, depending on the type of base. Remove any burr from the cut edges.
- Use an appropriate rust-inhibiting preparation to treat any bare metal surfaces.
- Place the rotor (including the base) on the roof taking care not to let the base drop off the spindle. Push the two steel locating pins fully through the small holes. The sealing gasket (already bonded to the underside of the base) should be in full contact with the roof.
- Slide the shutter element to the closed position and release the shutter from the clamp plate by gently deflecting the three retaining clips one at a time. Offer up the clamp plate to the underside of the roof, centring it on the steel shaft and taking care not to dislodge the rotor. If required, use the extension ring as a spacer between the roof and the clamp plate.
- Align the two small holes on the clamp plate with the steel pins on the base. Using a 13mm socket spanner (socket wrench) fasten the clamp plate to the roof with the M8 locking nut provided\*. The flat surface of the nut should face towards the roof. Tighten to a minimum torque of 2.0 Nm (1.5 lb ft). Do not exceed a torque of 8.0 Nm (5.9 lb ft) under normal circumstances or 3.0 Nm (2.2 lb ft) if the extension ring is used.
- Place the plug provided into the central recess of the clamp plate, turning it if necessary to ensure it presses fully home. It is important that the plug is fitted correctly.
- If continuous ventilation is essential remove the blue sliding element from the shutter (the peg to which the button is attached must be cut to remove it). Otherwise set the shutter to the closed position. Align the three clips on the shutter assembly with the three slots on the clamp plate. Push the shutter assembly firmly home, ensuring that all three clips snap correctly into place.

*\*If the ventilator is removed and refitted a new locking nut with a nylon insert of the same type must be used.*

*Note: The Flettner TCX™ Ventilator with a standard base can be fitted as a replacement for the Flettner 2000 Ventilator without the need to cut new holes in the roof. In such circumstances all parts of the old ventilator including the base should be removed.*

**Figure 1 – Diagram of templates showing positions of holes (not to scale)**

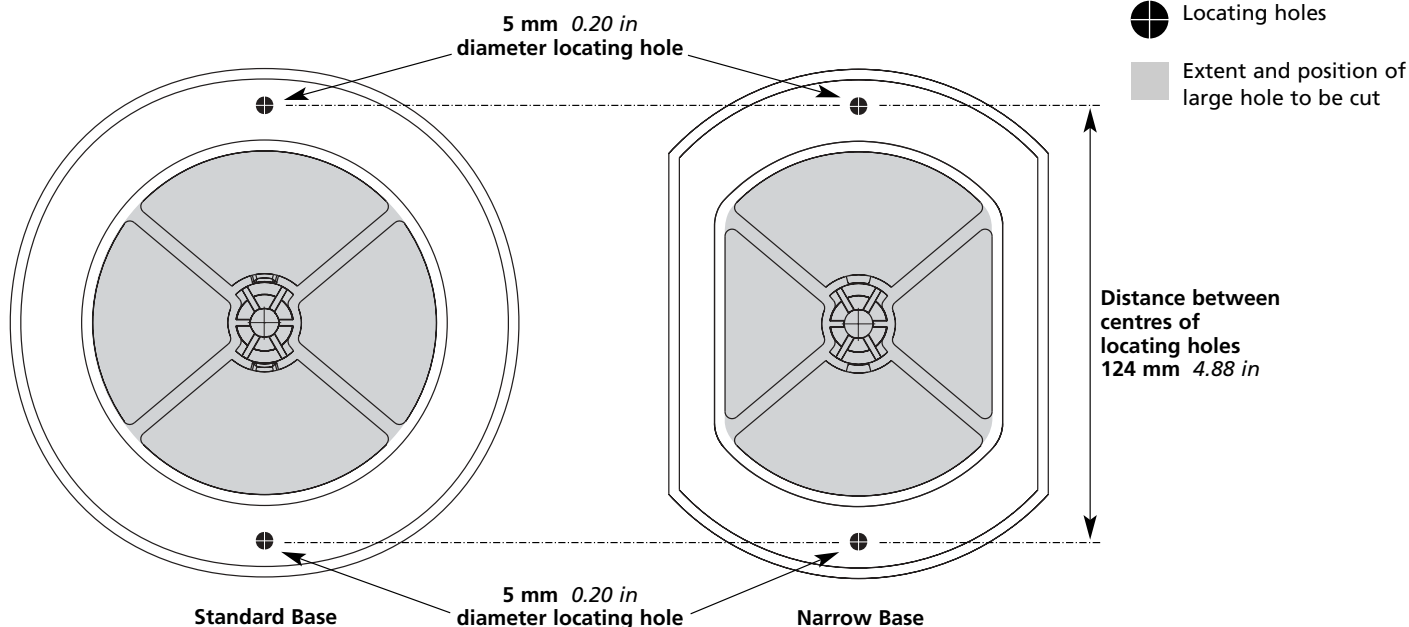

# Figure 2 – Actual Size Template for Standard Flettner TCX™ Base



## KEY

● Locating holes

■ Extent and position of large hole to be cut

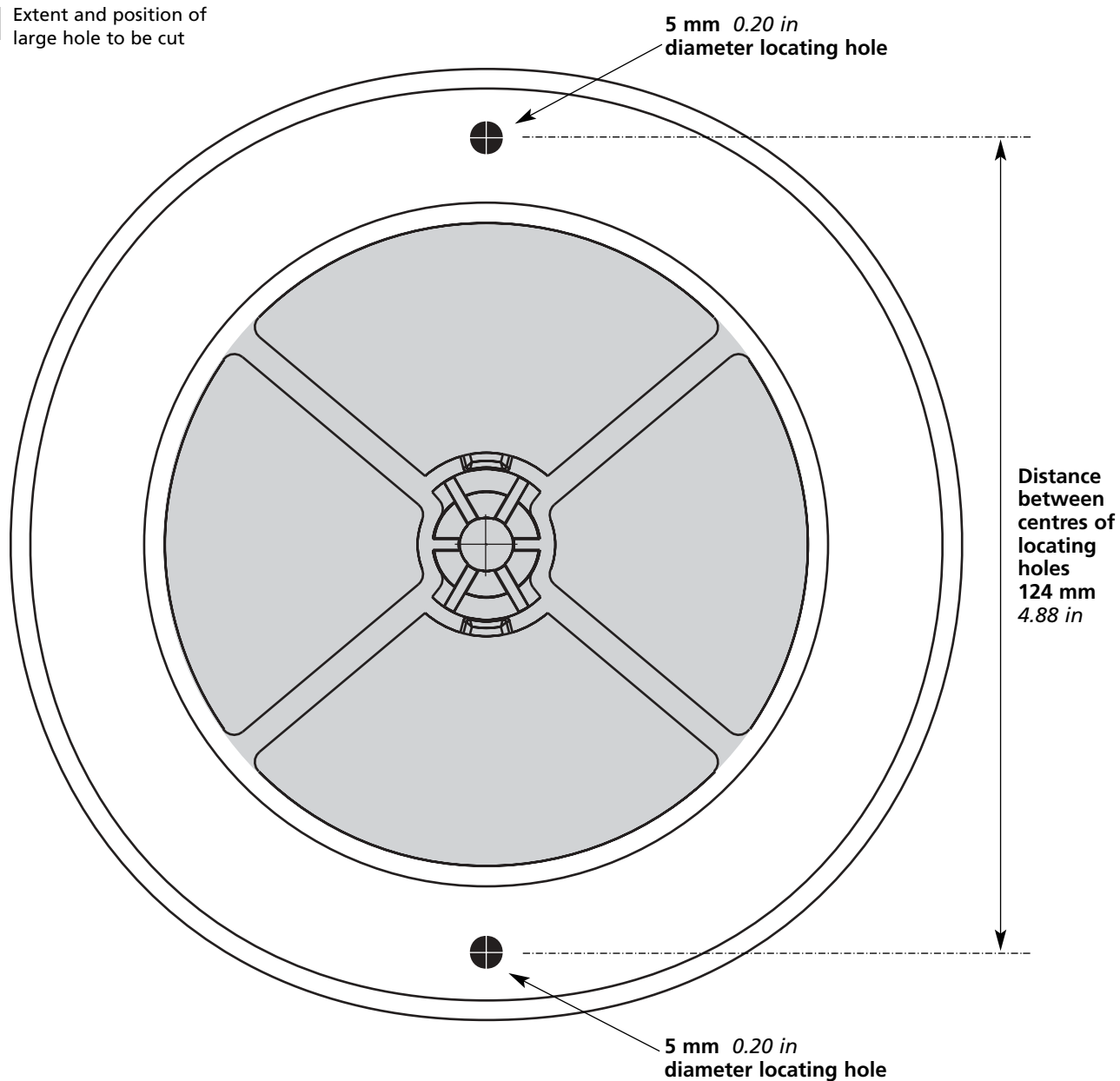

# Figure 3 – Actual Size Template for Narrow Flettner TCX™ Base



## KEY

● Locating holes

■ Extent and position of large hole to be cut

